

SB5560S 55A SCRs

FEATURES

- High thermal cycling performance
- High voltage capacity
- Very high current surge capability

APPLICATIONS

- Line rectifying 50/60 Hz
- Softstart AC motor control
- DC Motor control
- Power converter
- AC power coilitor
- Lighting and temperature control

Parameters Summary

VD/VR:1200/1600V IT(RMS):55A IGT :60mA

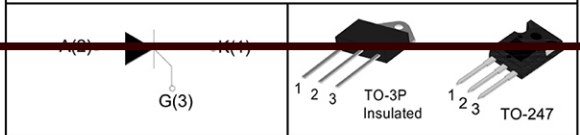

ABSOLUTE MAXIMUM RATINGS			
Parameter	Symbol	value	Unit
Storage junction temperature range	Tstg	-40 ~ 150	°C
Operating junction temperature range	Tj	-40 ~ 125	°C
Repetitive peak off-state voltage (T=25°C)	V _{DRM}	1200/1600	V
Repetitive peak reverse voltage (T=25°C)	V _{RRM}	V _{DRM} (DC Only)	V
Non repetitive surge peak Off-state voltage	V _{DSM}	V _{DRM} +100	V
Non repetitive peak reverse voltage	V _{BSM}	V _{RRM} +100	V
RMS on-state current	TO-3PIns.(TC=80°C)	I _{T(RMS)}	55
	TO-247(TC=85°C)		
Non repetitive surge peak on-state current	I _{TSM}	550	A
Average on-state current (180° conduction angle)	I _{T(AV)}	35	A
I ² t value for fusing (tp=10ms)	I ² t	1500	A ² S
Critical rate of rise of on-state current (I=2×IGT, tr ≤ 100 ns)	di/dt	150	A/μS
Peak gate current	I _{GM}	5	A
Average gate power dissipation	P _{G(AV)}	2	W

Thermal Resistances			
Symbol	Parameter	Value	Unit
Rth(j-c)	Junction to case (DC)	TO-3P	0.65
		TO-247	0.60
			°C/W

Electrical Characteristics (Typical values unless otherwise specified)

Symbol	Test Conditions	MAX	MIN	CO
V_{DM}	V_{DRM} at $f=125\text{ Hz}$	1000	1000	1000
I_{DRM}	V_{DM} at $f=125\text{ Hz}$	1000	1000	1000
I_{RRM}	V_{DM} at $f=125\text{ Hz}$	1000	1000	1000

Electrical Characteristics (Typical values unless otherwise specified)

Symbol	Test Conditions	MAX	MIN	CO
V_{TM}	V_{DRM} at $f=125\text{ Hz}$	1000	1000	1000
I_{DRM}	V_{DM} at $f=125\text{ Hz}$	1000	1000	1000
I_{RRM}	V_{DM} at $f=125\text{ Hz}$	1000	1000	1000

Ordering Information Scheme

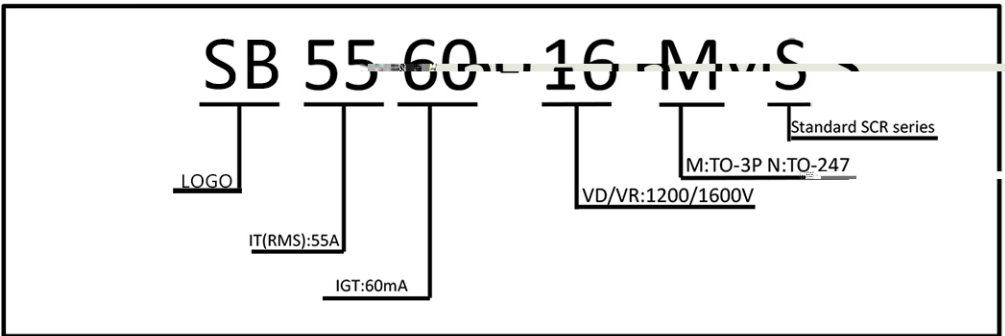

TO-3P Package Mechanical Data

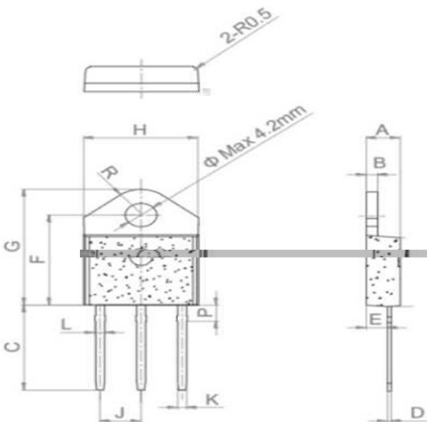

Ref.	Dimensions	Notes
A	4.00	
B	1.00	
C	15.02	
D	16.32	
E	15.02	
G	15.02	
H	15.02	
J	15.02	
K	15.02	

TO-247 Package Mechanical Data

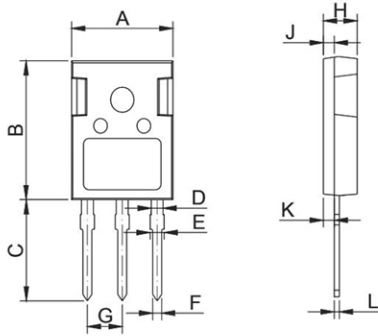

Ref.	Dimensions					
	Millimeters			Inches		
	Min.	Typ.	Max.	Min.	Typ.	Max.
A	15.50	15.80	16.30	0.610	0.622	0.634
B	20.80	21.00	22.20	0.819	0.827	0.874
C	19.70	20.00	20.30	0.776	0.787	0.799
D	1.80	2.00	2.00	0.071	0.079	0.079
E	1.90	2.10	2.30	0.075	0.083	0.091
F	1.00	1.20	1.40	0.039	0.047	0.055
G		5.44			0.214	
H	4.80	5.00	5.20	0.189	0.197	0.205
J	1.90	2.00	2.10	0.075	0.079	0.083
K	2.20	2.35	2.50	0.087	0.093	0.098
L	0.41	0.60	0.79	0.016	0.024	0.031

FIG.1 Maximum power dissipation versus on-state current

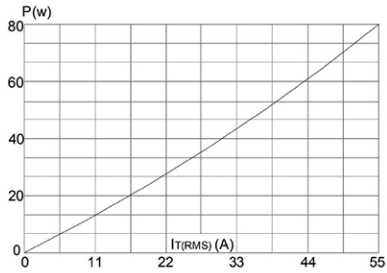

FIG.2: on-state current versus case temperature

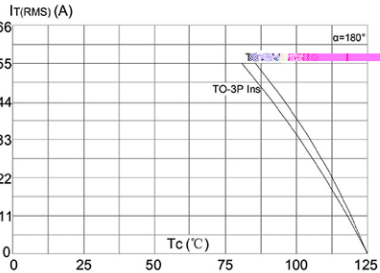

FIG.3: Surge peak on-state current versus number of cycles

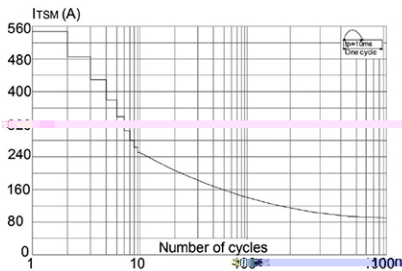

FIG.4: On-state characteristics (maximum values)

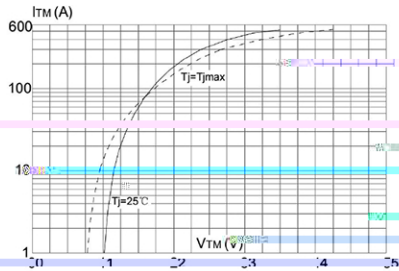

FIG.5: Non-repetitive surge peak on-state current for a sinusoidal pulse with width $t_p < 10\text{ms}$, and corresponding value of $12 t$

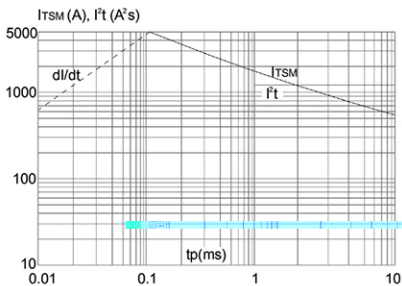

FIG.6: Relative variation of I_{GT} , $I_{H\&L}$ and I_{GT} versus temperature

