

7.0A, 700V, $R_{DS(on)(T_p)} = 1.2 @ V_{GS}=10V$

Low Gate Charge

Low C_r

100% Avalanche Tested

Fast Switching

Improved d/d Capabili

High Frequency Switching Mode Power Supply

Active Power Factor Correction

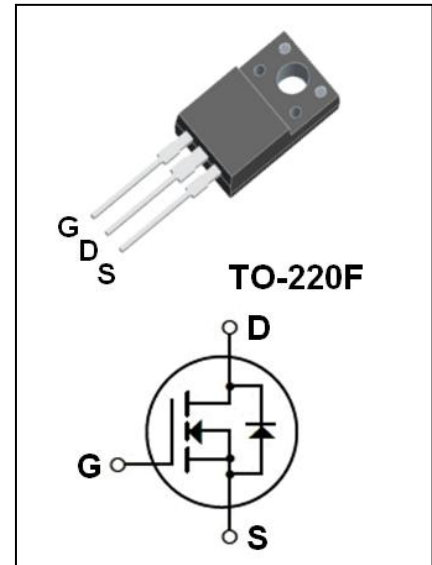

($T_c=25^\circ C$ unless otherwise noted)

Symbol	Parameter	Value	Unit
V_{DSS}	Drain-Source Voltage	700	V
I_D	Drain Current - Continuous - Continuous ($T_c=25^\circ C$) - Continuous ($T_c=100^\circ C$)	7.0*	A
		4.5*	A
I_{DM}	Drain Current - Pulsed (Note 1)	28*	A
V_{GSS}	Gate-Source Voltage	± 30	V
E_{AS}	Single Pulsed Avalanche Energy (Note 2)	590	mJ
I_{AR}	Avalanche Current (Note 1)	7.0	A
E_{AR}	Repetitive Avalanche Energy (Note 1)	14.0	mJ
d/d	Peak Diode Recovery d/d (Note 3)	4.5	V/n
P_D	Power Dissipation ($T_c = 25^\circ C$) - Derate above $25^\circ C$	48	W
		0.38	W/ $^\circ C$
T_j	Operating Junction Temperature	150	$^\circ C$
T_g	Storage Temperature Range	-55 to +150	$^\circ C$

Drain Current Limited by Maximum Junction Temperature.

Symbol	Parameter	Max	Unit
R_{JC}	Thermal Resistance, Junction to Case	2.6	$^\circ C / W$
R_{JA}	Thermal Resistance, Junction to Ambient	62.5	$^\circ C / W$

(Tc=25°C unless otherwise noted)							
Symbol	Parameter	Test Condition	Min	Typ	Max	Unit	
BV _{DSS}	Drain-Source Breakdown Voltage	V _{GS} =0V, I _D =250 A	700	--	--	V	
ΔBV _{DSS} /ΔT _J	Breakdown Voltage Temperature Coefficient	I _D =250 A (Referenced to 25°C)	--	0.7	--	V/°C	
I _{DSS}	Zero Gate Voltage Drain Current	V _{DS} =700V, V _{GS} =0V	--	--	1	A	
		V _{DS} =560V, Tc=125°C	--	--	10	A	
I _{GSSF}	Gate-Body Leakage Current, Forward	V _{GS} =+30V, V _{DS} =0V	--	--	100	nA	
I _{GSSR}	Gate-Body Leakage Current, Reverse	V _{GS} =-30V, V _{DS} =0V	--	--	-100	nA	
V _{GS(th)}	Gate Threshold Voltage	V _{DS} =V _{GS} , I _D =250 A	2.0	--	4.0	V	
R _{DS(on)}	Static Drain-Source On-Resistance	V _{GS} =10 V, I _D =3.5A	--	1.2	1.4		
g _{FS}	Forward Transconductance	V _{DS} =40 V, I _D =3.5A (Note 4)	--	6.5	--	S	
C _i	Input Capacitance		--	1380	--	pF	
C _o	Output Capacitance	V _{DS} =25V, V _{GS} =0V, f=1.0MHz	--	170	--	pF	
C _r	Reverse Transfer Capacitance		--	15	--	pF	
t _{d(on)}	Turn-On Delay Time		--	13	--	n	
t _r	Turn-On Rise Time	V _{DD} = 350 V, I _D = 7.0 A, R _G = 25 Ω (Note 4,5)	--	100	--	n	
t _{d(off)}	Turn-Off Delay Time		--	126	--	n	
t _f	Turn-Off Fall Time		--	48	--	n	
Q _g	Total Gate Charge	V _{DS} = 560 V, I _D = 7.0 A		9 + 1		ns	gBr ce

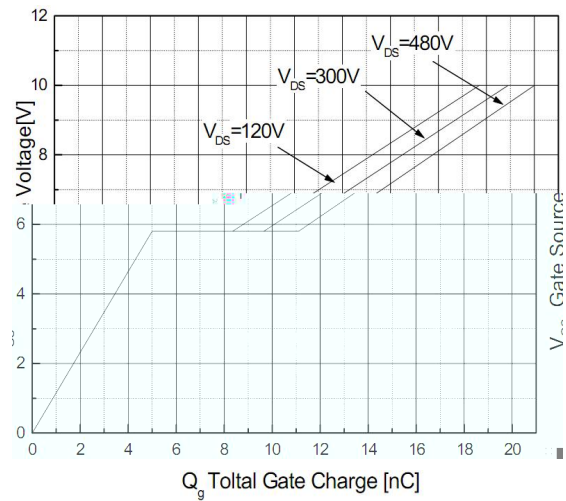
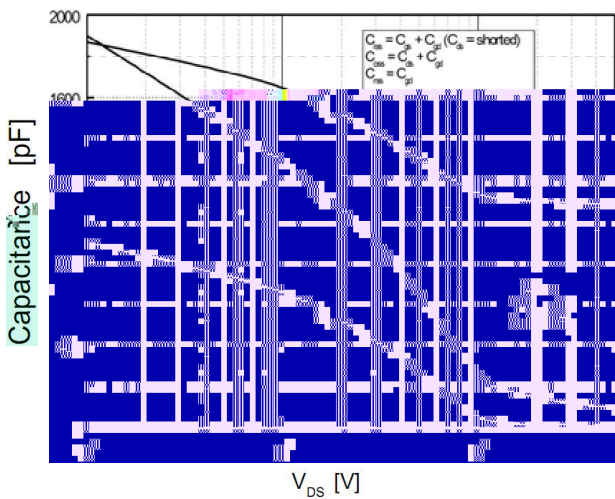
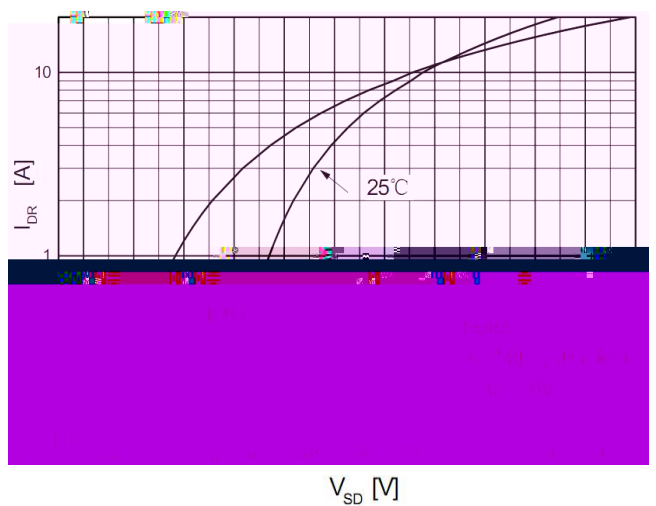
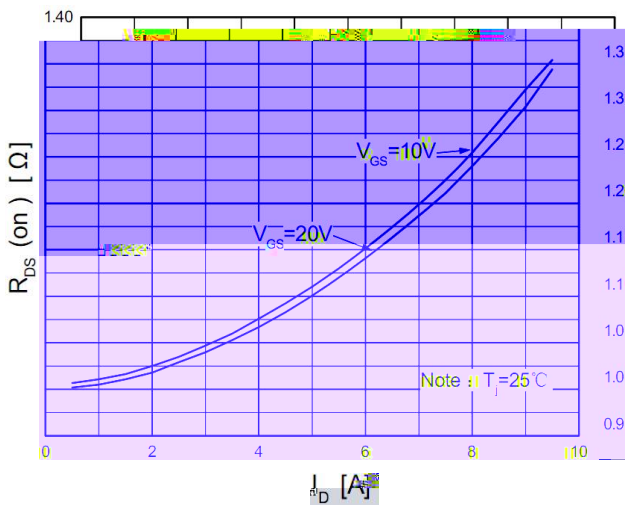
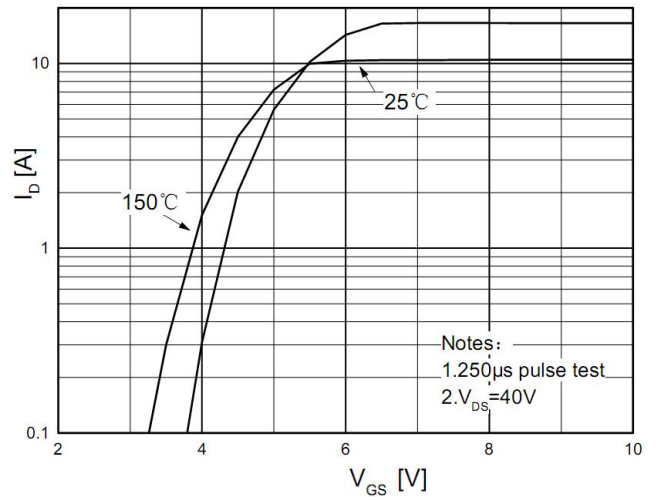
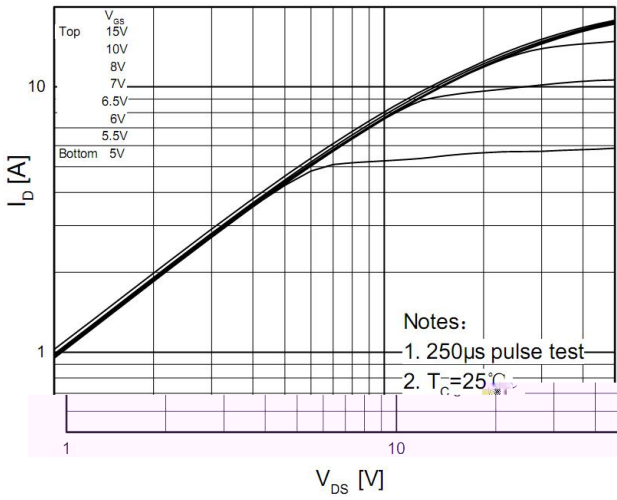

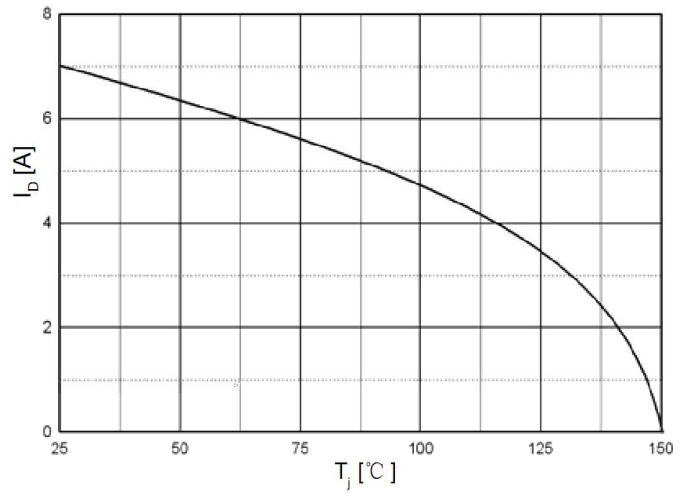
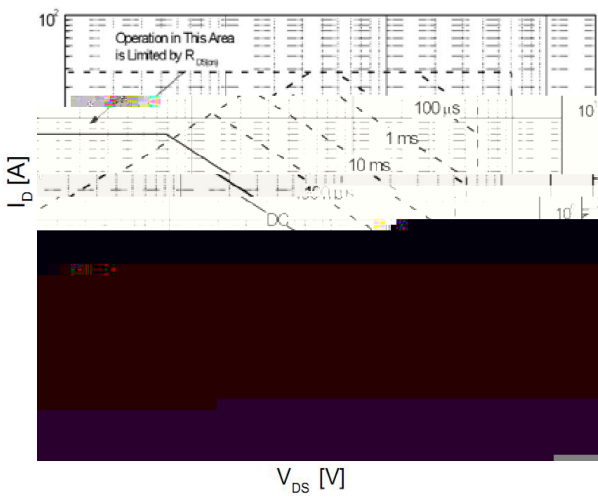
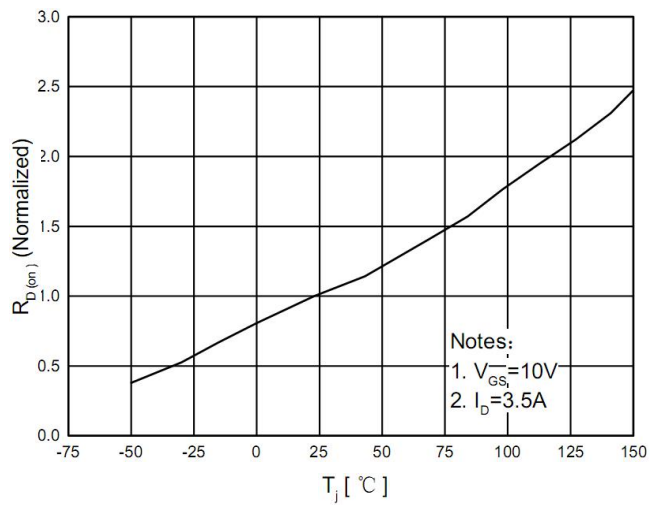
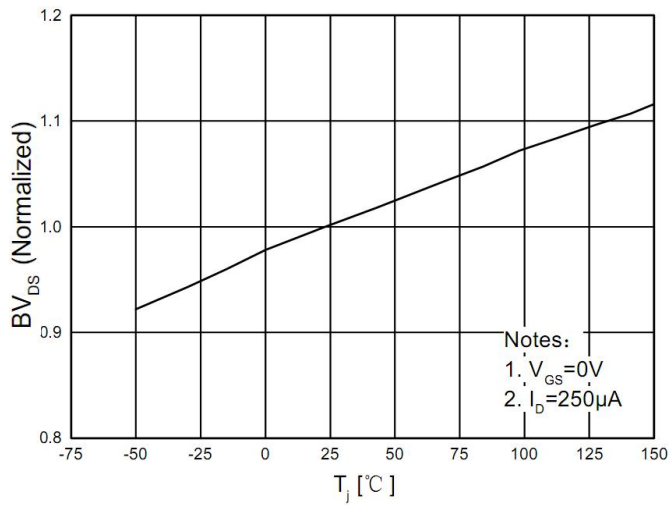

UNIT: mm

SYMBOL	min	nom	ma	SYMBOL	min	nom	ma
A	9.80		10.60	D		2.54	
A1		7.00		D1	1.15		1.55
A2	2.90		3.40	D2	0.60		1.00
A3	9.10		9.90	D3	0.20		0.50
B1	15.40		16.40	E	2.24		2.84
B2	4.35		4.95	E1		0.70	
B3	6.00		7.40	E2		1.0× 45°	
C	3.00		3.70	E3	0.35		0.65
C1	15.00		17.00	E4	2.30		3.30
C2	8.80		10.80			30°	

